

Tandem off-road trough tipping trailer TP22



Product benefits

- Proven and stable chassis construction with additional torsion tubes
- Best possible stability due to large tyre/wheel combination
- Best possible shock and wear protection due to specially edged Hardox trough
- Optimum load distribution due to inclined front wall
- Heavy-duty BPW swivel axle unit with bilateral axle load compensation for perfect grip on roads
- Hydraulically suspended 4 t drawbar for comfortable handling
- Connecting lines laid in the hose tower
- OPTIONAL: Designed for heavy rocks with increased floor and wall thicknesses
- OPTIONAL: Various tyre/wheel manufacturers (Alliance, Aeolus, BKT, NOKIAN, ...)
- OPTIONAL: Toolbox for extra stowing volume
- OPTIONAL: Shovel, broom, scraper mount
- OPTIONAL: Lighting package: extra front and rear working lights for good all-round visibility
- OPTIONAL: Top frame cover of corrugated aluminium
- OPTIONAL: Central lubrication system for all lubrication points
- OPTIONAL: Central lubrication ledge (greasing nipples pulled out)
- OPTIONAL: 2-hose hydraulic system for rapid lowering

Product details

TYPE DESIGNATION

2-AXLE-CENTRAL-AXLE HEAVY-DUTY-SEGMENT-TROUGH-TIPPING-TRAILER - OFF-ROAD - type: TP22
For handling bulk materials such as sand, gravel, rubble, ground excavation etc. on building sites

WEIGHTS

Gross train weight (perm.): 22 t
Gross weight (techn.): 28 t in off-road use with 4 t support load
Tare weight: approx. 5,9 t (+/- DIN tolerance)

DIMENSIONS

Internal length: approx. 5,300 mm
Internal width: approx. 2,330 mm
Loading space internal height: approx. 1,200 mm
Load volume: approx. 13,5 m³
Total width: max. 2,550 mm
Loading height unloaded: approx. 1,500 mm

FRAME

Central-axle welded steel frame construction in weight-optimised design
Lightweight frame made of high-strength fine-grain steel, for use with wide tyres with a total max. width of 2,550 mm

CHASSIS

BPW swing axle unit with drum brakes, 410/180 mm S-cam brake, 24 t/30 t payload, off-road model
Axle base 1,550 mm
1st and 2nd axles are rigid
Without axle lift

Tyres:
4 tyres 650/55 R 26.5"
4 steel rims 20.00 x 26.5"

TOWING DEVICE

Heavy-duty V drawbar in welded framework construction, hydraulically adjustable height approx. 500 mm and dampened with heavy-duty ball coupling K80

SUPPORT FIXTURES

1 front hydraulic support leg, support load 8 t, can be uncoupled when loaded, actuation via towing vehicle

BRAKE SYSTEM

Dual-circuit pneumatic braking system
Braking system make: Wabco
Hydraulic ALB controller
Without ABS - for tractor operation up to 40 km/h
Spring-loaded parking brake on both axles
Steel air tank 80 l
Brake/air connection lines with 2 single coupling heads yellow/red
Hose lines laid via hose tower

TIPPING TROUGH

Steel trough with reinforced base plate made of Hardox (HB450) and reinforced closed upper belt
Base thickness 6 mm = full base plate, wall thickness 6 mm
Front wall and rear wall inclined, full steel mudguard (valance) on both sides covering the external wheel area
Increased excavator protection
Special steel rear panel for extra-high opening with low-level payload, extra hinge and lateral latching mechanism including double-acting hydraulic cylinders with overcentre valve for hydraulic actuation from the tractor, no chute

HYDRAULICS

Hydraulic supply for 2-pipe hydraulics with 4 or more double-acting control units for: tipping, drawbar, jack, rear wall
(oil filling volume approx. 40 l)
1x front-mounted press tipping mechanism for rearward tipping at approx. 55 °

ROLLER TARPAULIN

Without roller tarpaulin and not equipped for it

ELECTRICAL EQUIPMENT

12/24 volt lighting unit
2 full-LED rear lights
2 LED front position lights
2 LED rear marker lights
LED side marker lights
2 LED license plate lights
Fixed connection cable with 1 x 13-pole plug with adapter to 7-pole

PAINTWORK

Steel granulate cleaning, zinc dust priming and spray painting with 2-component commercial vehicle acrylic paints (RAL or truck standard colour)

Plastic parts and hot-dip galvanised parts unpainted, powder-coated black add-on/installation parts

LABELLING

Schwarz Müller lettering on the side
Schwarz Müller lettering at the rear
Side reflecting contour marking strips in white/silver across entire length of sides and two top corners of skip, according to ECE 48
Rear reflective contour marking strips in red, circumferential full contour markings, according to ECE 48

ACCESSORIES

Rear mudguards made of galvanized steel sheet, with splash guard
Fixed steel form tube underride guard
2 wheel chocks, according to regulations, with mounting on the front panel
Noise damper = rubber pads

ATTACHMENTS

Side collision protection made of aluminium profiles according to regulations

Product impressions



A proven and sophisticated solution ensuring perfect stability in the rear end area throughout the entire tipping process.



This special frame design of large profiled steel pipes is the main supporting element. Crossbars provide extra stability throughout the entire tipping process.



BPW's 30 t heavy-duty swing axle unit with bilateral axle load compensation plus its 650/55 R26.5" tyres ensure a perfect grip on roads and outstanding off-road performance.

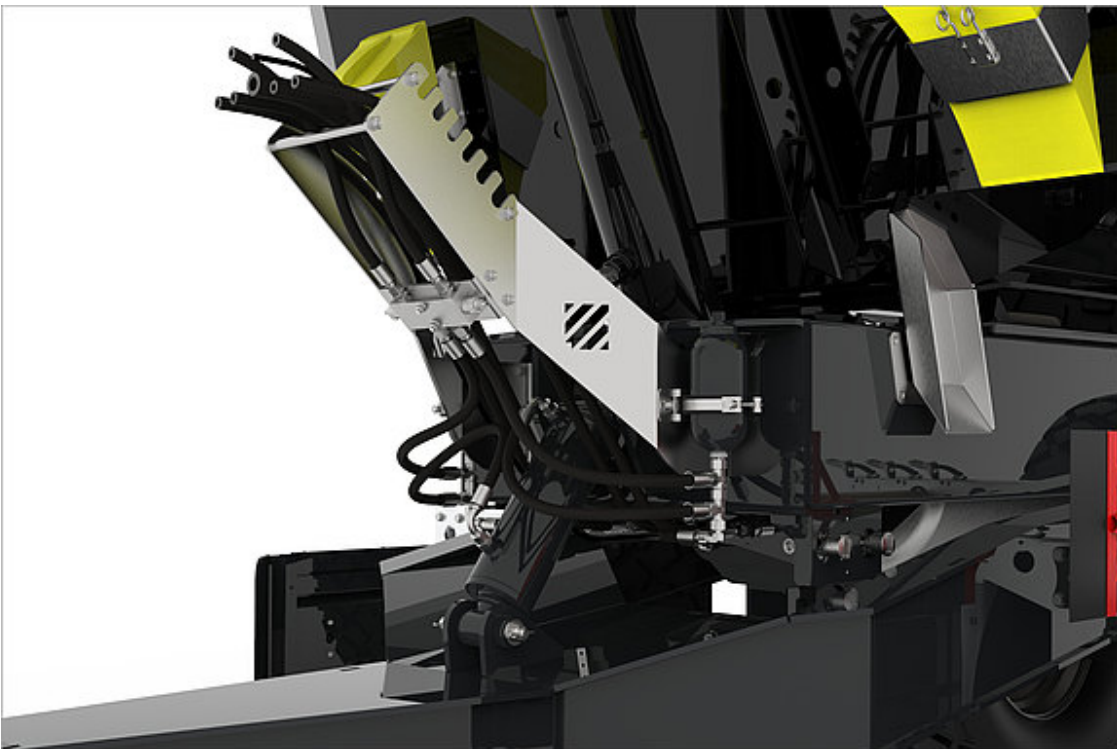

The V-shaped drawbar is designed for up to 4 t of load and is equipped with a convenient hydraulic damping mechanism. It absorbs every impact and yields a comfortable driving response.

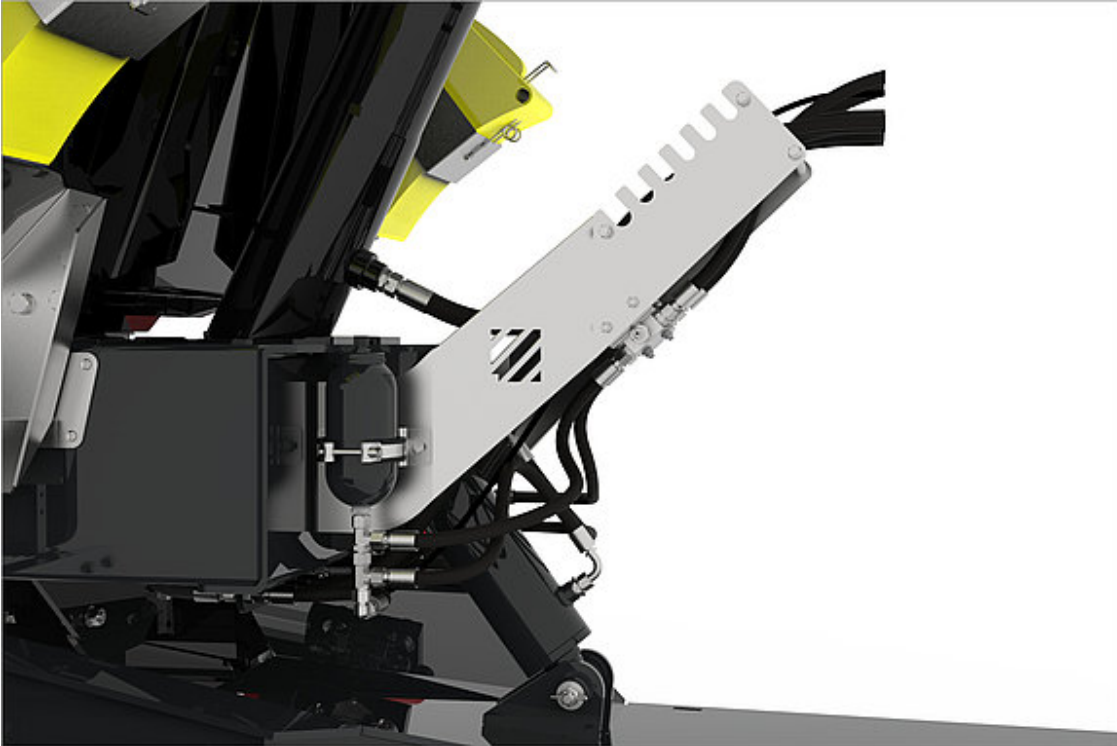

To ensure a perfect connection to the tractor, all connecting lines are protected in a hose duct.



All light is produced by LEDs in vehicle lamps that are mounted in protected places and support multi-volt operation (12/24V).



OPTIONAL: The LED tail lamps are mounted in a protected place. Their removable wire mesh guard enhances the safety of every service use (wire mesh guards not permitted on public roads).



OPTIONAL: The heavy-duty rock tipper of 100% Hardox (HB450) with 8 mm floor and 6 mm side walls will help you handle even the toughest jobs.

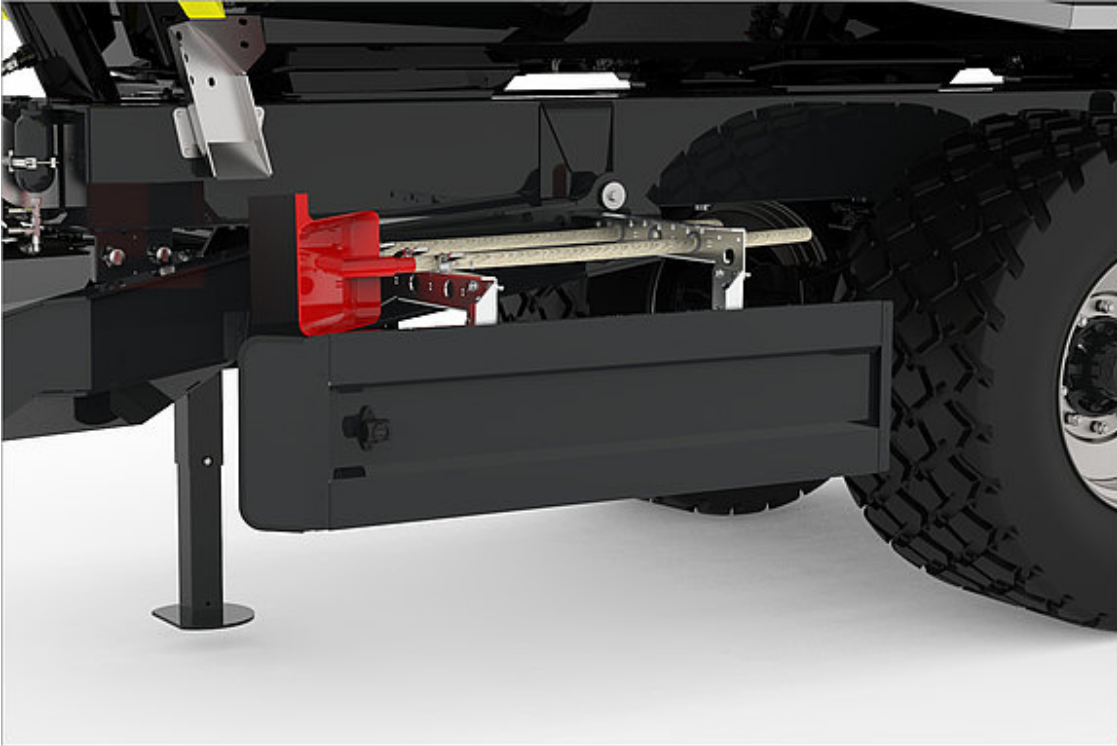

OPTIONAL: Side impact protection gives you extra safety in road traffic (compulsory in many countries).

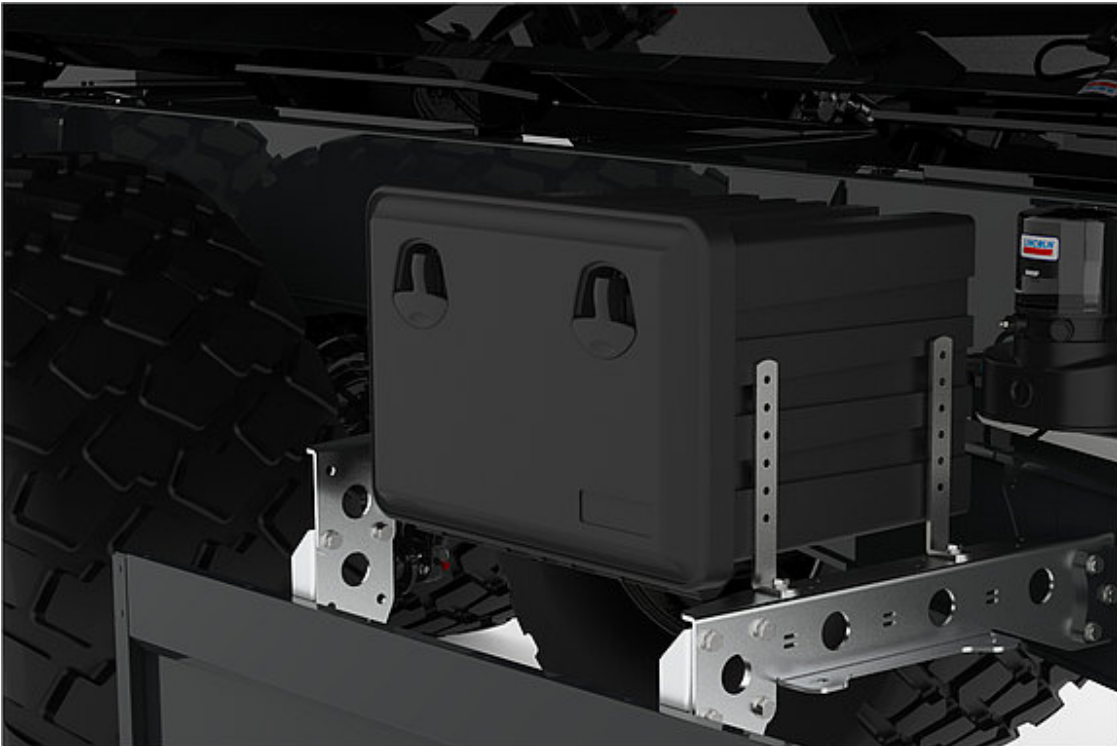

OPTIONAL: Plastic toolbox for extra stowing volume

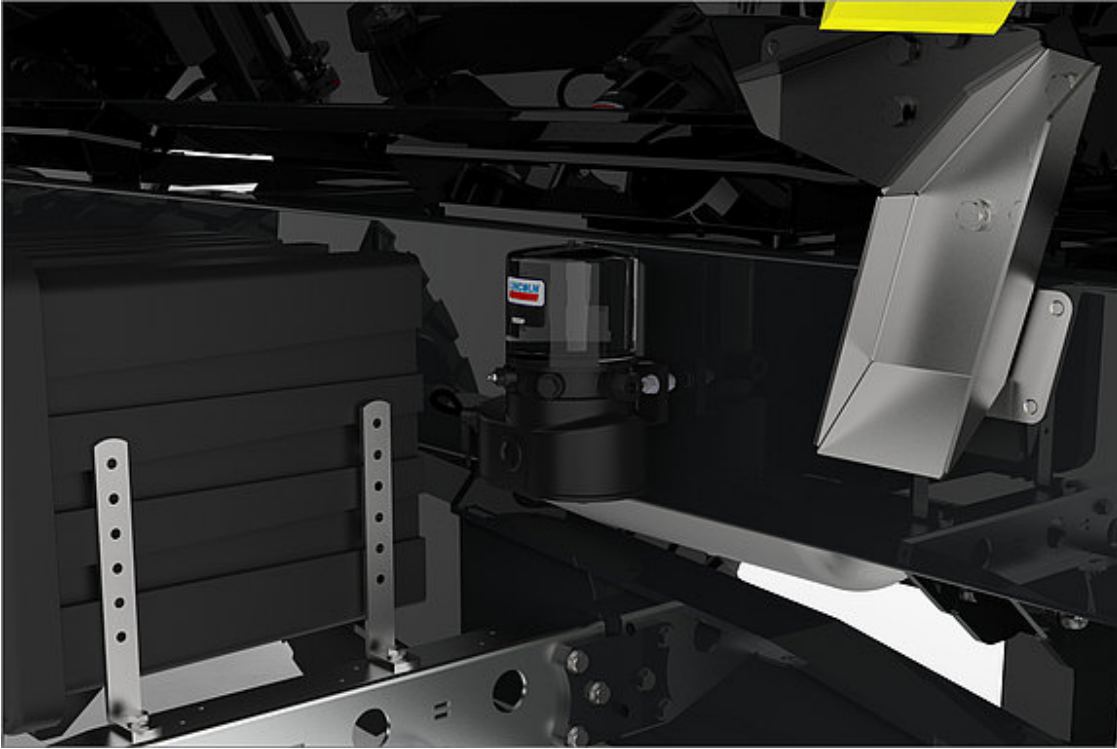

OPTIONAL: The central lubrication unit provides the entire vehicle with the required lubrication.



OPTIONAL: 2 reversing lamps and 4 lateral working lamps for good all-round visibility.

