

Full aluminium 3-axle large-scale tipper semitrailer



Product benefits

- Stable and torsionally rigid chassis design with extra torsion shafts
- Automatic lowering device for maximum stability
- High-quality front tilt cylinder with four-point support
- High-quality, hollow profile aluminium body for high resistance to impact and wear
- Standing platform at front wall for operating the roller tarpaulin
- Foldable, trapezoidal aluminium underride protection for practical filling of screw conveyors etc.
- Grain feeder in door leaf with dosing lever and water guard plate
- Axles from well-known manufacturers such as SAF or BPW
- Combined rear wall - fully opening, centrally divided double door with hinged frame and automatic locking mechanism
- Body sizes available for different cargo volumes
- Inclining cambered roof bars for extra stability and protection against unwanted water pooling
- OPTIONAL: Side-mounted control panel providing all control and monitoring elements
- OPTIONAL: Wear plates at rear of body for longer body life

- OPTIONAL: Removable discharge funnels (straight or conical) with optional dust bag

Product details

TYPE DESIGNATION

FULL ALUMINIUM 3-AXLE LAGE-SCALE TIPPER SEMITRAILER
for easily sliding bulk goods, pallet and grain transport

DIMENSIONS

Internal length: approx. 10,000, 10,500, 11,500, 13,300 mm

Internal width: approx. 2,470mm

Internal height: approx. 2,000, 2,200, 2,300, 2,500 mm

Cargo volume: approx. 49, 52, 54, 57, 60, 62, 65, 76, 82 m³

Max. total width: 2,550 mm

Max. total height (unloaded): approx. 3,470 – 3,970 mm

Fifth wheel height: approx. 1,200 mm

Loading height (unloaded): approx. 1,470 mm

FRAME

Welded aluminium frame design with rear tipping shaft
Replaceable 2" kingpin

TIPPER BODY

Aluminium corner body in pallet design = smooth inside and outside, vertical front and rear walls,
discharge chute not included

Reinforced front wall without excavator protection

Side and rear walls made from hollow profiles with upper frame on top

Crosspiece at back = pivoting door lock rod including actuation rod

Uniform fixed support across front wall and rear crosspiece

End-to-end floor panel with narrow cross ribs

(warping after welding may provoke minor corrugation)

Completely seal-welded inside of side walls

Combination rear wall = centrally divided double door with 1 external espagnolette and door latch
each plus extra double hinged frame including automatic locking mechanism and shutoff of sliding
discharge gate

1 grain feeder (approx. 400/400 mm) per door leaf with side-mounted dosing lever and water guard
plate

PAINTWORK

Primer and top coats spray painted with 2-component acrylic varnishes for commercial vehicles
Black plastic parts not painted
Powder-coated black attachments/mountings
Hot-dip galvanised parts not painted

ATTACHMENTS

Aluminium platform with aluminium safety grating, guard rail and ladder included
Aluminium side impact protection profiles
Spare wheel bracket not included
1 aluminium ladder, bracket included
Labelling, operating and safety instructions in German
Licence plate frame
Rear marking pursuant to ECE
CE mark of conformity

WEIGHTS

Gross weight (techn.): 39 t
Axle assembly load (techn.): 27 t
Fifth-wheel load (techn.): 12 t
Tare weight: approx. 5,7 t or heavier (+/- DIN tolerance)

ACCESSORIES

1 level gauge (to check horizontal position)
3 pairs of plastic single wheel mudguards with spray protection as per regulations
Unpainted folding trapezoidal aluminium underride protection, aluminium latch included
2 wheel chock and holders as per regulations
Removable grain feeder discharge funnel, dust bag not included, mounted on chassis
Noise dampers = rubber pads

LANDING GEAR

Aluminium support jack, 2 x 12 t, mechanically operated on the right, including pivot foot, further options to choose from

AXLES

SAF Intradisc axles with disc brakes
Axle load: 9 t/axle, on-road models
Wheelbase: 1,310 + 1,310 mm
Automatically lifting front axle

WHEELS

6x 385/65 R 22.5, 160K tyre

6x 11.75 x 22.5 steel or aluminium rim
Spare tyre not included

BRAKES

Brake system pursuant to EC Directives 71/320 and/or ECE R13
Two-line compressed air brake system
Wabco brake system
EBS system plus RSS stability programme
Spring-loaded parking brake on 2 axles
Steel or aluminium air tank
2 separate yellow/red brake/air line couplings
Electronic air suspension with automatic lowering device operated by inductive switch and lowering lock operated by rotary switch on semitrailer
Hose or cable connections to semitrailer tractor not included

HYDRAULICS

1-tube system with screw coupling
Hydraulic hose connection to semitrailer truck not included
High-pressure front cylinder for backward tipping, tipping angle: approx. 45 degrees

TARPAULIN

Plastic roller tarpaulin incl. aluminium slat and hand crank on right in travelling direction
Horizontal tarpaulin bracket rope fastening, 3 stop brackets plus holder for rolled-up tarpaulin; tarpaulin hook at front and back with zig-zag tie fastening
3 central removable and swivelling rube crosspieces = also serve as tarpaulin support, approx. 100 mm inclination
Tarpaulin attached on left in travelling direction by means of 4 tension belts (rubber pads included) and turnbuckles on tipper body's underside

LIGHTING/ELECTRICAL EQUIPMENT

24 V lighting system pursuant to EC Directive 76/756/EEC
2 five-chamber LED tail lights
2 LED front marker lights
2 LED rear contour lights
LED side marker lights
2 licence plate lights
2 7-pin sockets (1x DIN ISO 3731, 1x DIN ISO 1185) and 1 15-pin socket (DIN ISO 12098)
Power connection(s) to semitrailer tractor not included

LABELLING

White reflecting contour marking strips on entire bottom length of side walls plus 2 top corners

pursuant to ECE 48

Red reflecting circumferential contour marking strip at back pursuant to ECE 48

Product impressions



Torsion box: A proven and sophisticated solution ensuring perfect stability in the rear end area of tipper semitrailers throughout the entire tipping process.



Torsion shafts: These special cross members work like the torsion box to add extra stability to the tipper semitrailer throughout the entire tipping process.

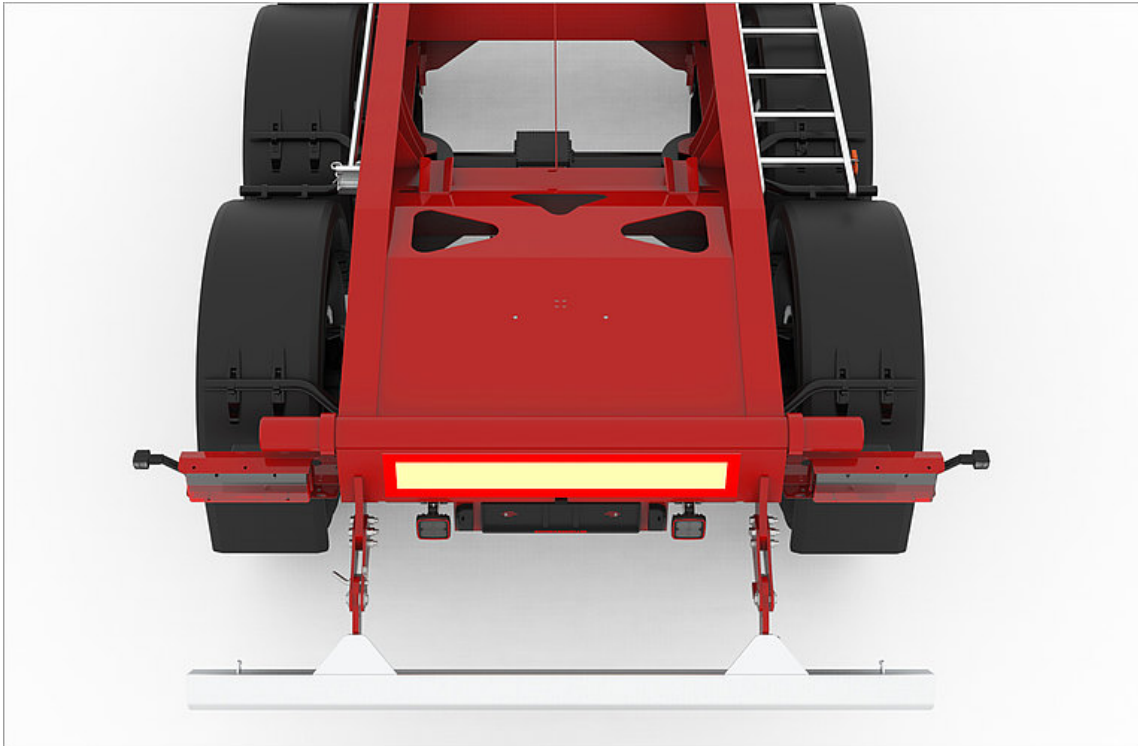

One-part tipper shaft: The tipper shaft is not only welded on the side but all the way along. What you get is enhanced stability while tipping.

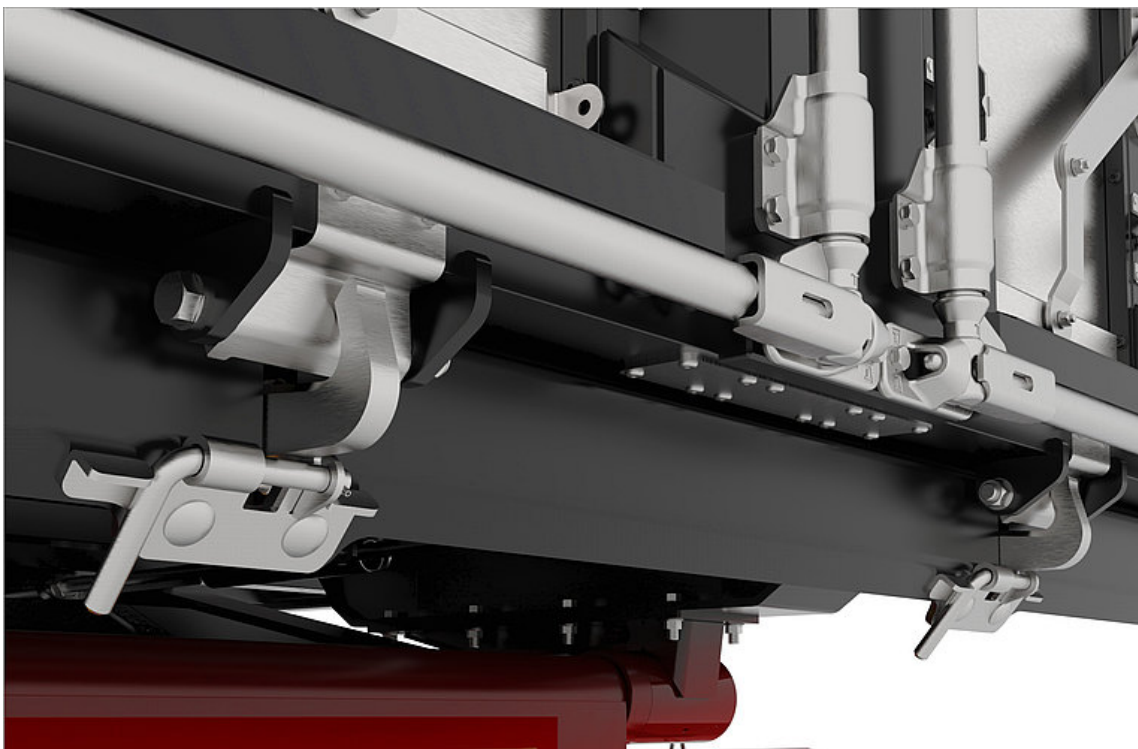

Automatic hinged door/flap latch: A special linkage assembly automatically unlatches the hinged rear wall then tipping and also re-latches it when lowering the box.

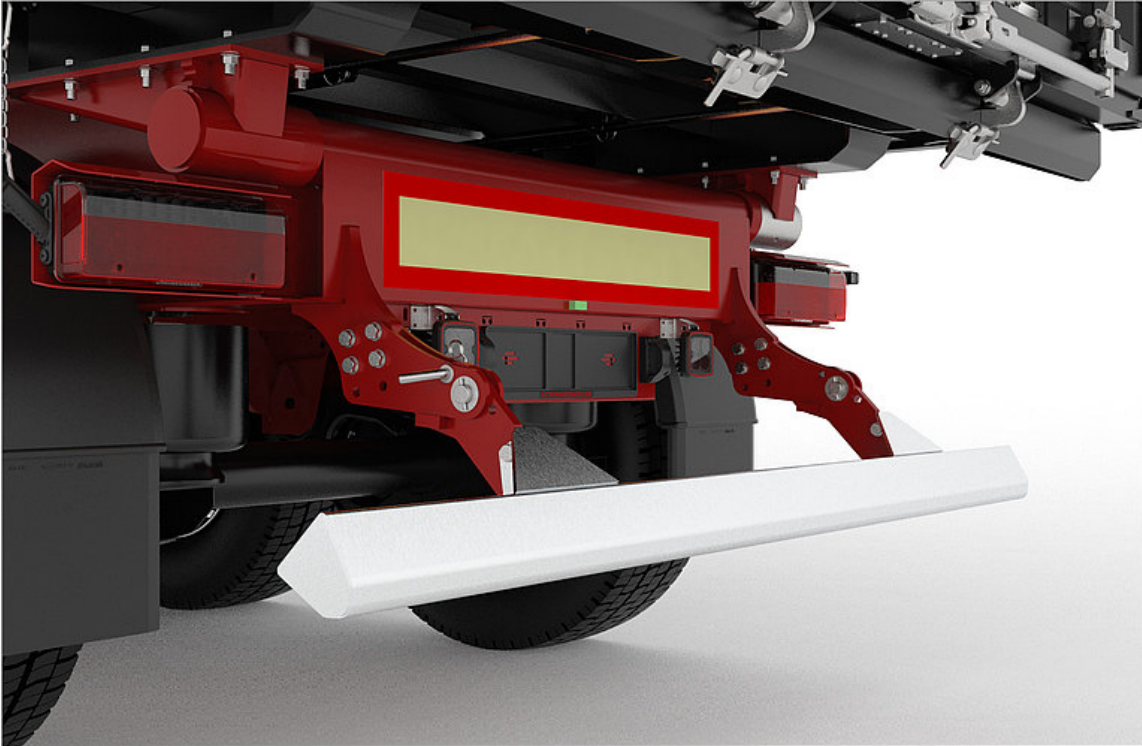

Foldaway underride protection: Standard underride protection models tip up to maintain the chassis clearance required for hopper feeding.



Four-point support: The press tipping mechanism is supported at four points (two at the top and two at the bottom). This substantially improves tipping stability compared to a three-point support.

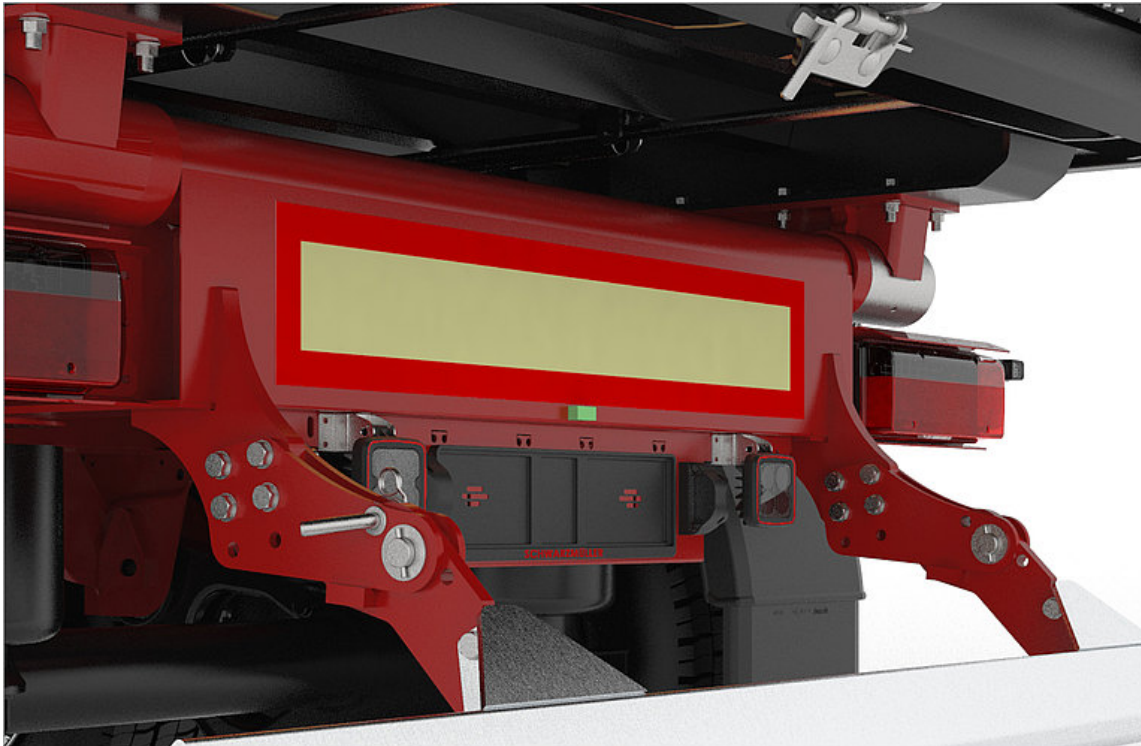

Rear level gauge: The level gauge on the end plate is an easy-to-use means of checking the horizontal orientation to reduce the risk of accidents.



Grain feeder: The large grain feeders and their user-friendly control levers can be mounted in various positions.

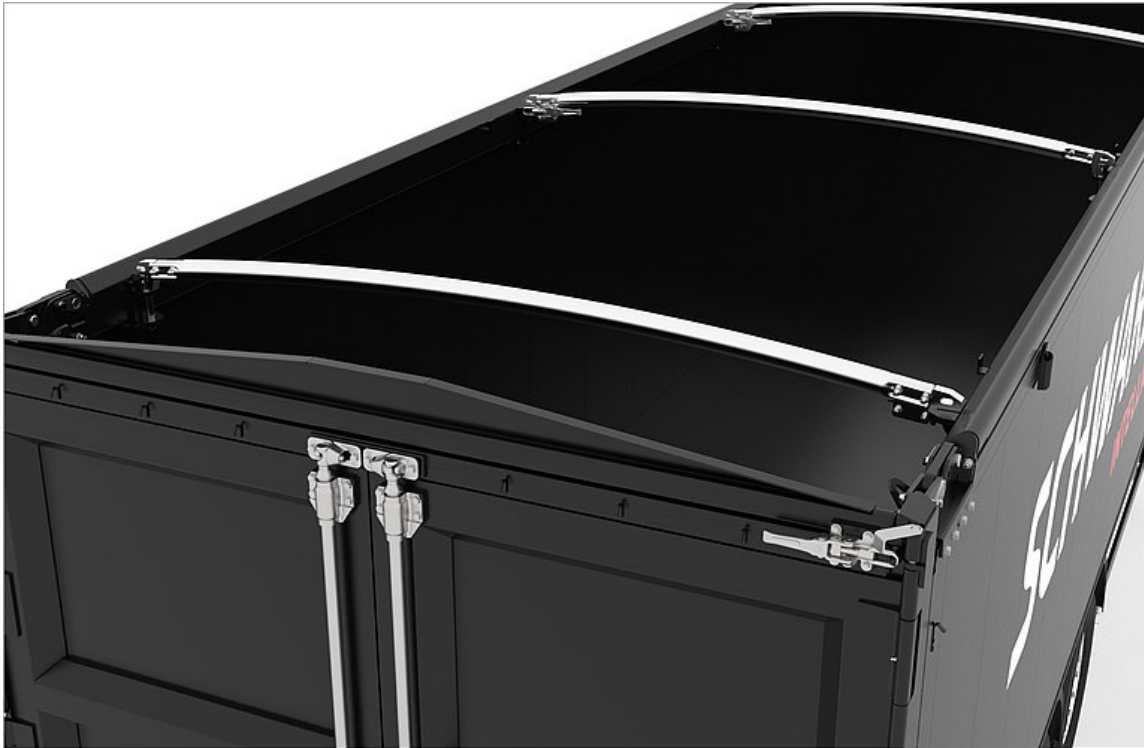

Cambered roof bar: The material-repellent roof bar are cambered to add stability to the tipper box. They can be pivoted to support different loads, and their inclination reduces potential water pooling.



OPTIONAL: Platform: Use the platform to climb the box, monitor the loading process and open or close the tarpaulin.

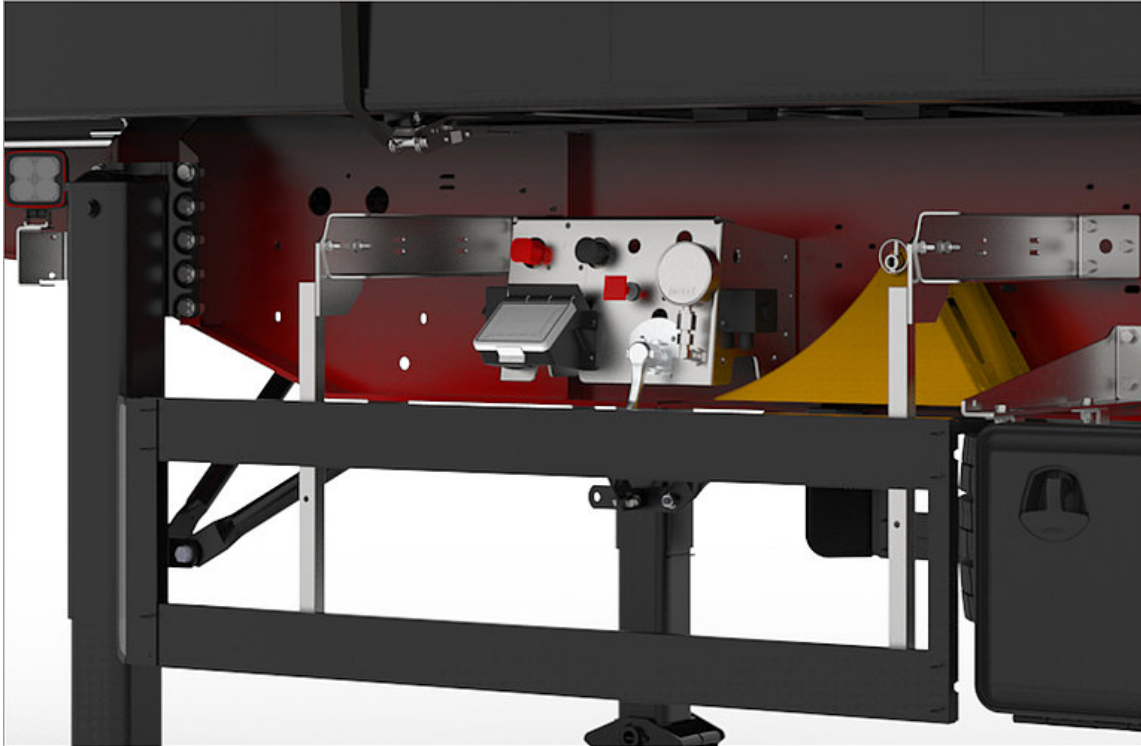

OPTIONAL: Control panel: Arrangement shared by control elements such as brake release valves, lifting and lowering mechanism, trailer monitoring or lowering lock for easier use.



OPTIONAL: Roller tarpaulin: A roller tarpaulin protects the cargo against the weather and a potential loss of material. It unrolls and rolls up from the platform and is secured by quick-action or tension belts.

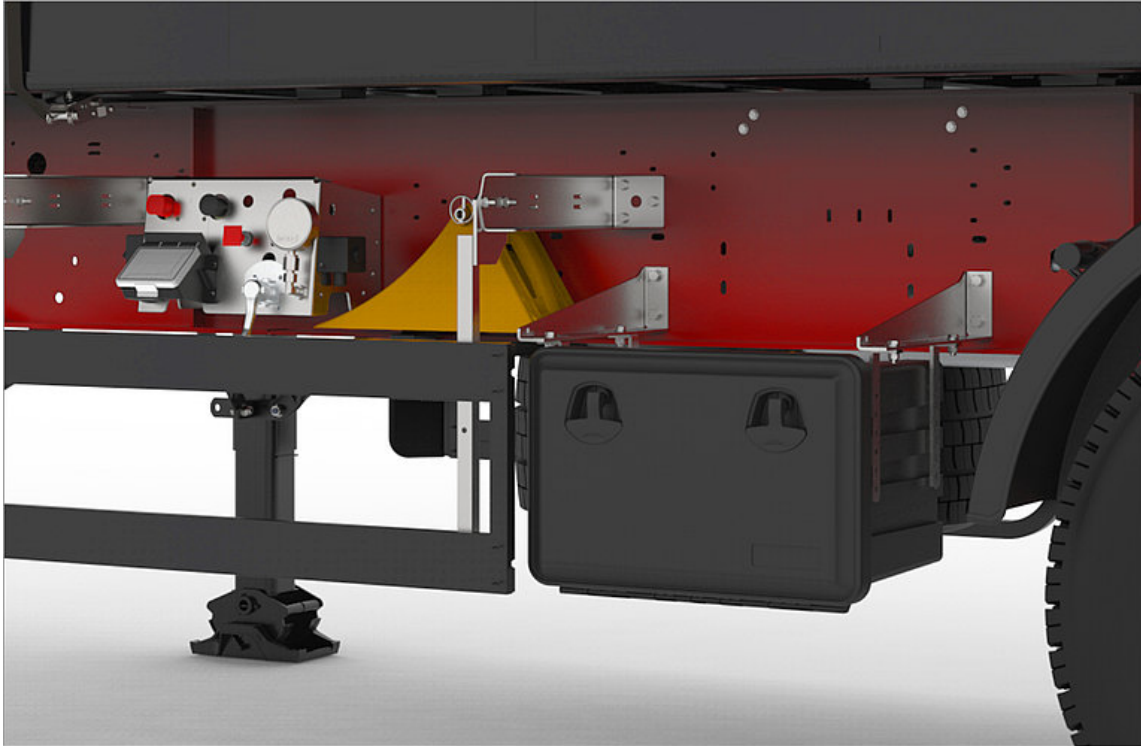

OPTIONAL: Toolbox: Toolboxes of various sizes can be optionally mounted on the vehicle.



OPTIONAL: Aluminium wear plates: Reinforcements at the rear tipper box end reduce wear and therefore extend the useful life.



OPTIONAL: Ladder: This climbing aid eliminates the hazards involved in climbing into and out of the tipper box for maintenance and cleaning.



OPTIONAL: LED lights: Standard tail lamps are partly equipped with LEDs. Or choose a full-LED design variant.

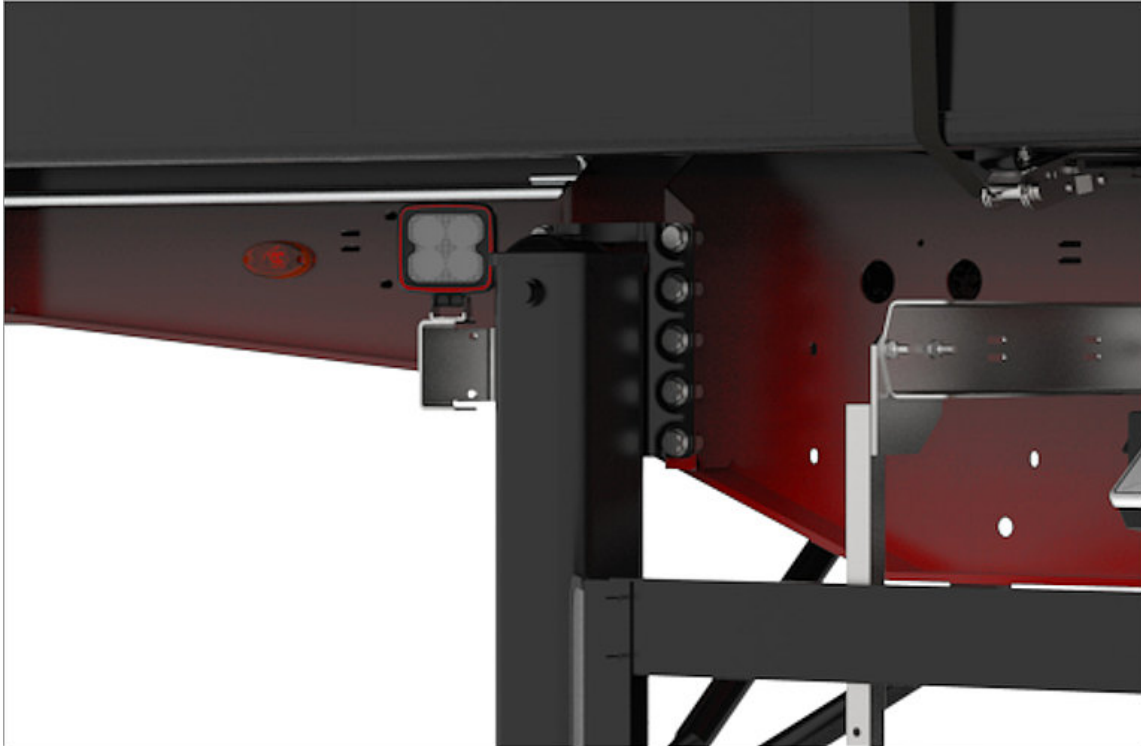

OPTIONAL: Working lights: Working lights enhance your field of vision in the dark or when objects cannot be seen properly.

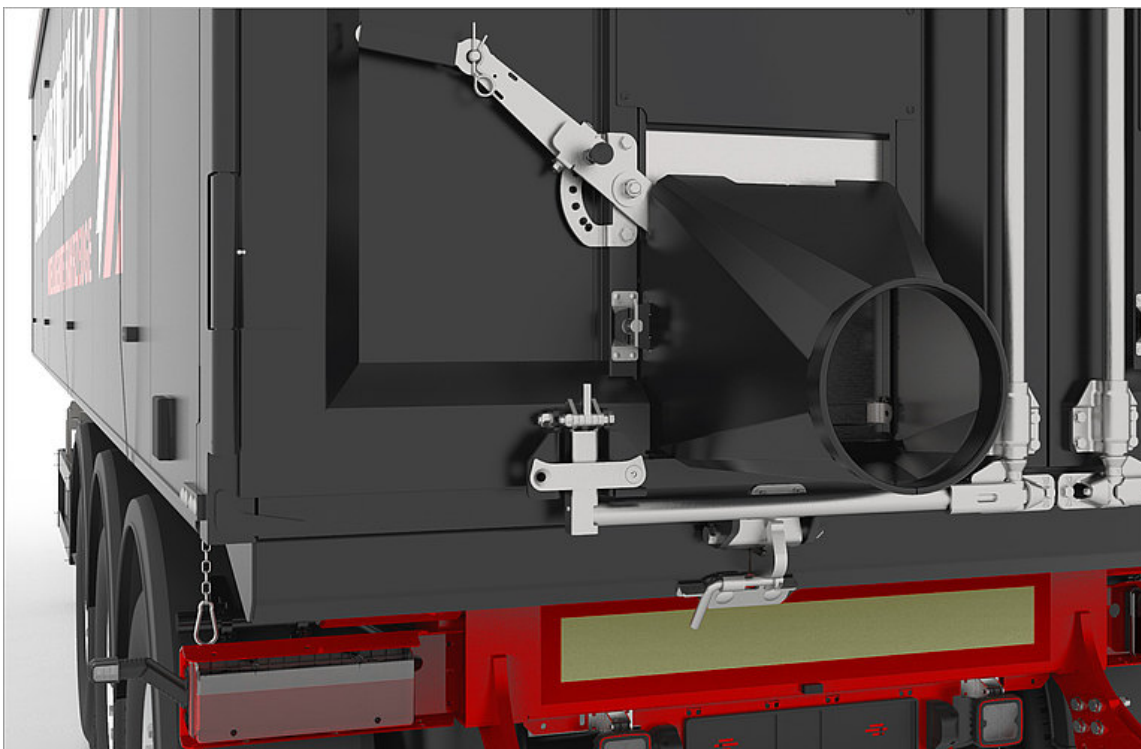

OPTIONAL: Discharge funnel: Removable discharge funnel - either parallel or conical - for accurately guiding the flow of material being discharged.



OPTIONAL: Dust bag: Simple means of avoiding the formation of dust.

